

3200-3ERX15 CRANE

USER MANUAL

Effective Serial Number: 5369

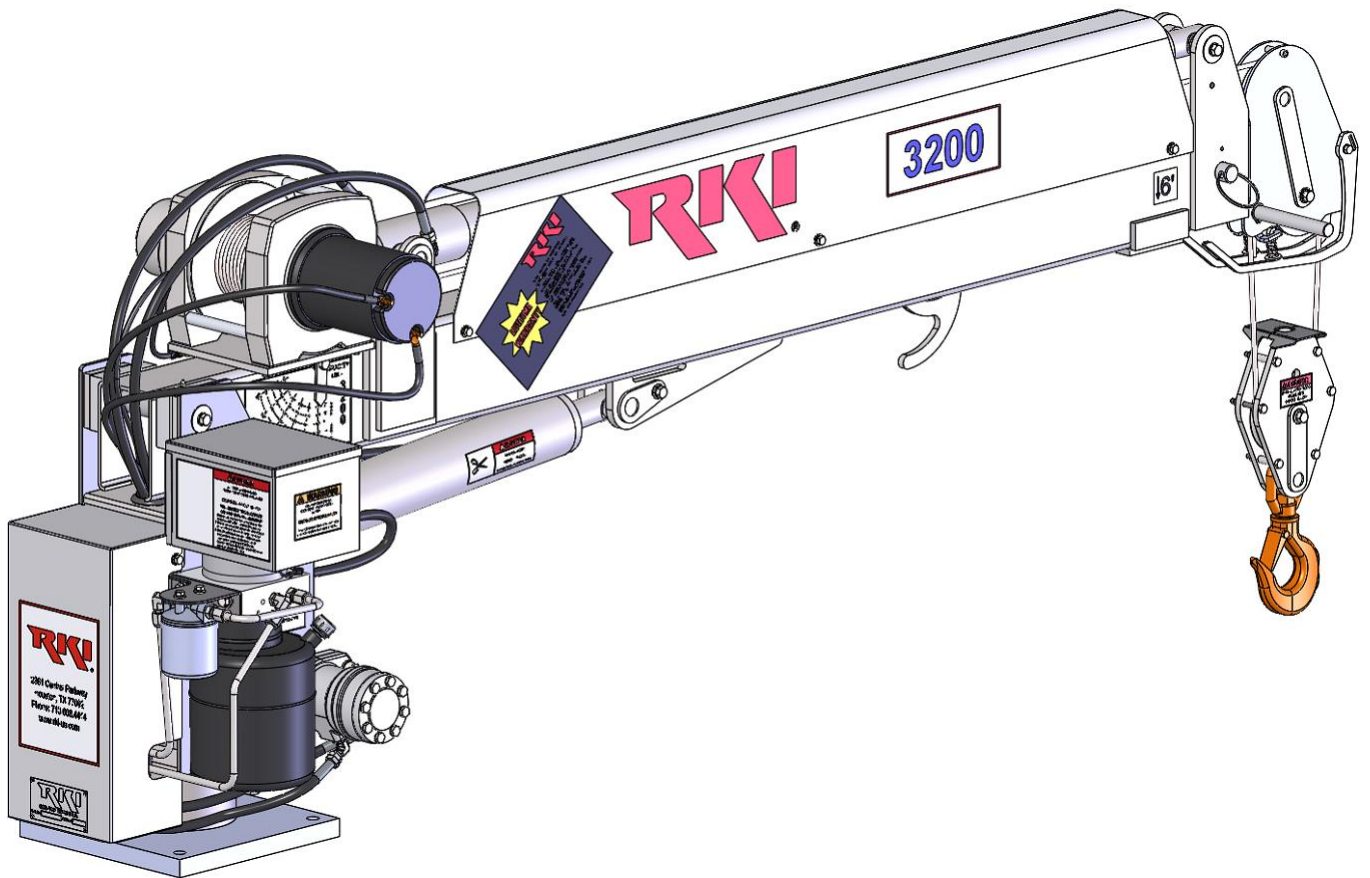

Serial Number: _____

Date: _____

RKI, Inc.

2301 Central Parkway

Houston, TX. 77092

Phone: 713-688-4414

Fax: 713-688-8982

www.rki.com

TABLE OF CONTENTS

Description	Page(s)
PACKING LIST & MOUNTING KIT	2
IMPORTANT NOTICE	3
SPECIFICATIONS	4
OVERALL DIMENSIONS	5
CAPACITY CHART	6
INSTALLATION INSTRUCTIONS	7-8
OPERATING INSTRUCTIONS	9-11
INSPECTION & MAINTENANCE SCHEDULE	12
LUBE & HYDRAULIC FLUID SPECIFICATIONS	12
TURRET ASSEMBLY	13-18
BOOM ASSEMBLY	19-20
WIRING SCHEMATIC	21
ELECTRICAL LAYOUT	22-23
HYDRAULIC LAYOUT	24
TRAVEL BLOCK ASSEMBLY	25
ANTI TWO-BLOCK SYSTEM	26
OVERLOAD SENSOR CALIBRATION	26
REPLACEMENT PARTS & ACCESSORIES	27
TROUBLESHOOTING	28
LIFETIME WARRANTY	29

PACKING LIST

The following items are included with your RKI 3200-3ERX15 crane:

- 1 – Crane Assembly
- 1 – Crane User Manual (W0053)
- 1 – Remote Control: ERX model (45366): Tethered, 21ft with Emergency Stop
- 1 – Mounting Kit (43746)

ITEM	PART #	QTY	DESCRIPTION
1	07885	1	WASHER-FLT 3/8 N
2	07892	8	WASHER-FLT 5/8 W
3	40911	1	BOLT-HX 3/8-16X7/8
4	43512	6	CLIP-BODY F/BATTERY CABL
5	43738	1	WIRE ASY-#02 36.0 GRND
6	43739	4	BOLT-HX 5/8-11X3 G8
7	43740	4	NUT-HX 5/8-11 G8
8	45155	1	BRKT-3200 SWITCH MSTR
9	45156	1	SWITCH-MSTR CUTOFF
10	45157	1	WIRE ASY-PWR CRANE 12"
11	45158	1	WIRE ASY-PWR BATTERY 25'
12	45174	1	FACEPLATE-SWITCH MSTR
13	45366	1	REMOTE-3200ERX/4000 21FT
14	*43211	1	CONNECTOR-CABLE FEM SKT

* INCLUDED WITH CRANE POWER WIRE (ITEM 10)

SWITCH ASSEMBLED TO BRACKET

IMPORTANT NOTICE

RKI, Inc. cannot possibly know or even anticipate all of the varied uses and applications that may be found for its crane products. For that reason, the company expressly disclaims any and all responsibility for the manner and methods used by the installer of these products. The company recommends that the installer of its crane products follow sound engineering principles and comply fully with each and every applicable ANSI, OSHA or other safety standard.

Safety Warning: RKI, Inc. cranes are not intended to be used, or incorporated as a component of any other equipment which may be used for the lifting or moving of people. Any such use is absolutely and categorically contrary to RKI, Inc.'s recommendation.

INTRODUCTION:

RKI cranes are designed and manufactured to provide you years of safe, dependable performance.

This manual has been provided to give you specific information regarding the safe operation and upkeep of your crane.

It is very important that all who operate or service the crane should begin by thoroughly reading this manual. In addition, the supervisor, and others concerned with the operation of the crane, should read this manual. Remember that an uninformed or careless operator can make the operation of any equipment dangerous.

The information in this manual helps to insure that your RKI crane is installed properly and operated safely. However it is not a definitive guide to every possible situation or circumstance. If you have any questions or require additional information, please contact RKI.

SPECIFICATIONS

Model:

3200-3ERX15

Moment Rating:

10,000 ft. lbs

Lift Capacities:

3,200 lbs. @ 3 ft.

2,000 lbs. @ 5 ft.

1,429 lbs. @ 7 ft.

1,111 lbs. @ 9 ft.

909 lbs. @ 11 ft.

769 lbs. @ 13 ft.

667 lbs. @ 15 ft.

Boom:

The boom angle varies from -5° to +75°.

1st stage telescoping boom extension ranges from 7' to 11' (Power).

2nd stage telescoping boom extension ranges from 11' to 15' (Manual).

Line Speed: Approximately 7 feet per minute (first rope layer, double line).

Multi-Functions: The crane configuration allows multiple electric and hydraulic functions to be performed simultaneously, however, multiple hydraulic functions are limited.

Load Sensor:

A load sensor is standard to automatically protect overload.

Anti Two-Block:

Per OSHA 29 CFR Part 1926.1416(d)(3), An anti two-block feature is incorporated into the crane to prevent damage from contact between the travel block and the boom tip.

Winch Cable and Block:

62ft of 1/4" galvanized aircraft cable is supplied with traveling block for double line operation.

Electrical:

12 VDC required to operate the electrical solenoid valves control all the hydraulic functions and the contactor for the hoist winch.

Hydraulic:

Self-contained unit with 2500 psi, 0.5 GPM pump and 10 micron serviceable oil filter

Standards:

Meets or exceeds ANSI B30.5 and OSHA 1910.180 requirements.

Specifications:

- Weights: 706 lbs (product), 856 lbs (shipping)
- Overall Length: 8' 1" (retracted), 16' 1" (extended)
- Width: 1' 8"
- Height: 2' 11"
- Base Plate Dimensions: 12" x 12"
- Truck Requirements: 10,000 lbs. GVWR (Minimum)

Stabilizers and Boom Supports:

- Jack Legs, Outriggers, and Boom Supports are available. Call your distributor or RKI for details.

OVERALL DIMENSIONS

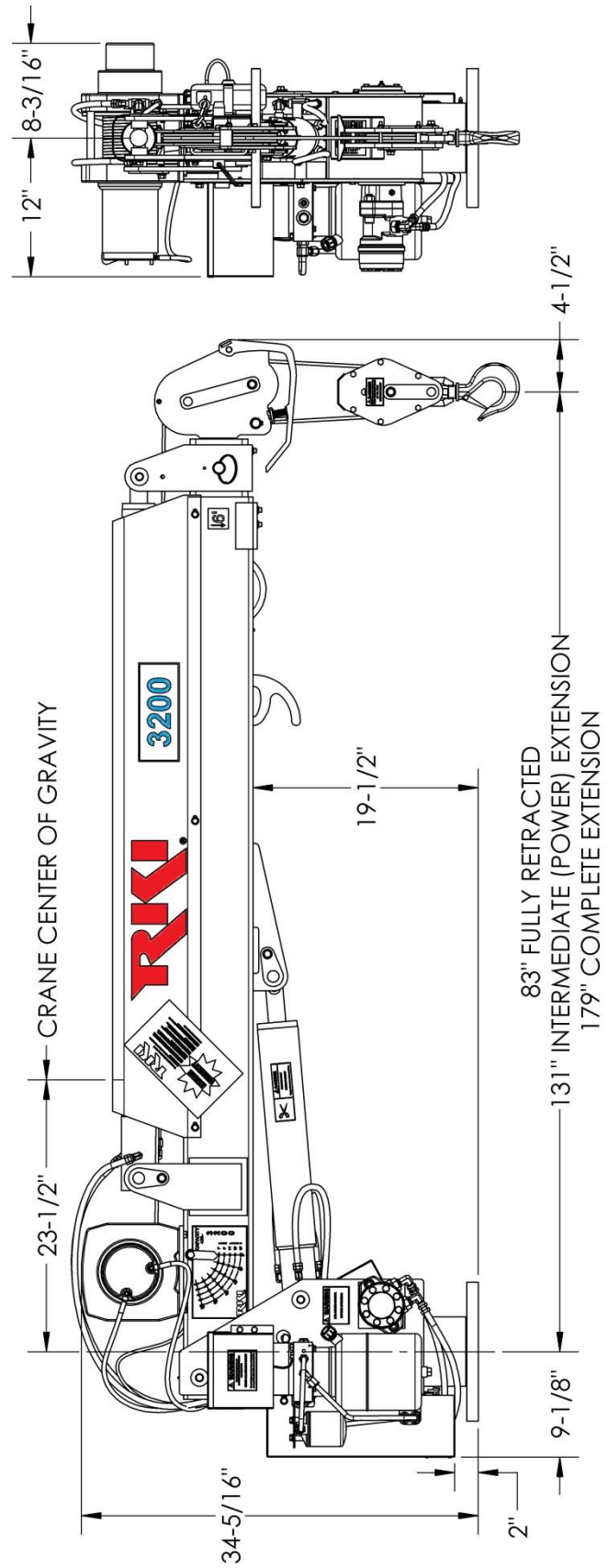
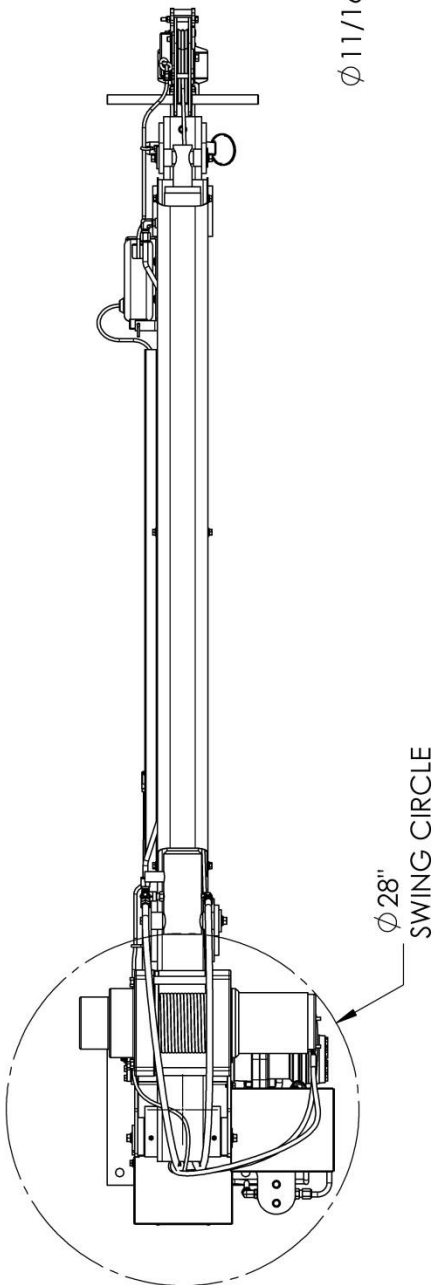
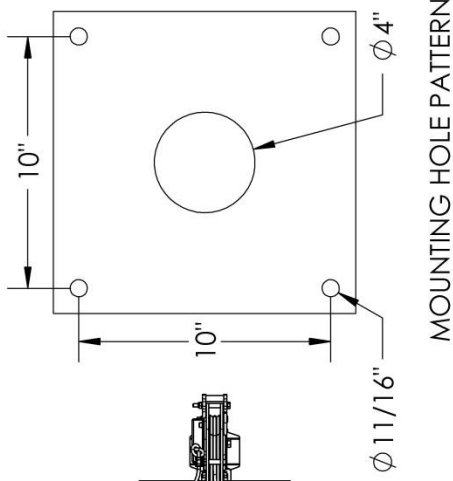

3200 SERIES CAPACITY CHART

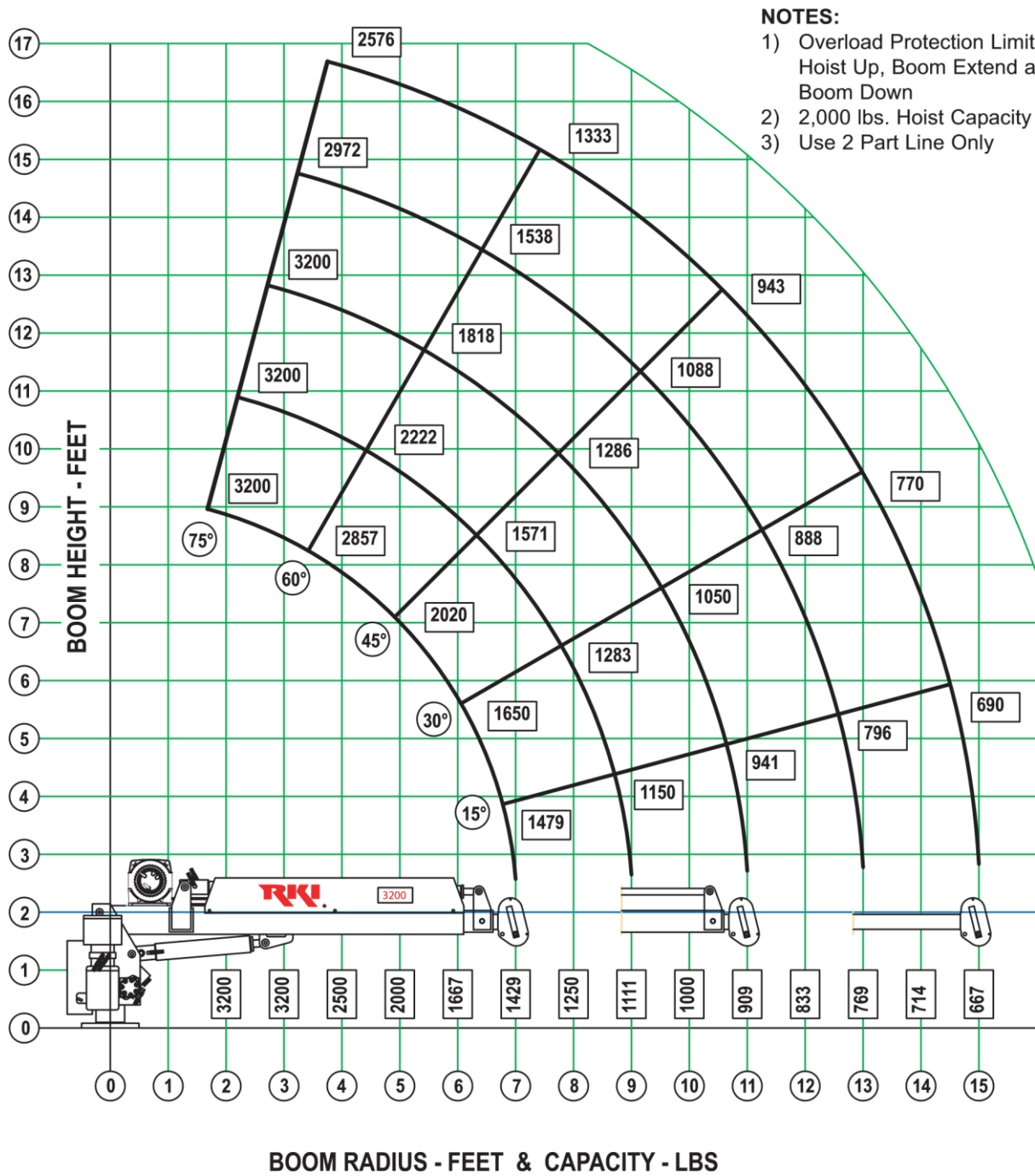

NOTES:

- 1) Overload Protection Limits:
Hoist Up, Boom Extend and
Boom Down
- 2) 2,000 lbs. Hoist Capacity
- 3) Use 2 Part Line Only

INSTALLATION INSTRUCTIONS

1. Vehicle should meet minimum GVW rating of 10,000 lbs.
2. The crane mounting base must be capable of safely supporting the crane assembly and its maximum capacity of 10,000 ft-lbs loading. The support structure for the mounting base must be tied directly to the main frame members of the vehicle.
3. The vehicle must be equipped with jacklegs extending out at least 42" from the centerline of vehicle.
4. Disconnect the ground cable from the vehicle's battery(ies).
5. Drill four $\varnothing 11/16$ " holes on a 10" square pattern to match the mounting holes in the crane's base plate. Drill or cut a $\varnothing 4$ " hole centered on the crane mounting pattern. This $\varnothing 4$ " hole provides clearance for routing of the power and ground wires through the base plate.
6. Install the crane boom support, positioned directly under the crane's main boom. To prevent damage to the crane, do not support the crane under the hydraulic cylinders.
7. The crane is electrically grounded through the tapped hole provided in at the bottom of the base quill. Attach the #2ga ground cable to this tapped hole with a 3/8-16 bolt, and then secure the ground cable to the truck's frame. The crane's ground cable may also be attached to a service or utility body, provided the service or utility body itself is grounded to the truck's frame.
8. Lift the crane using the lifting rings and place on the mounting location. Install 5/8-11 Grade 8 mounting bolts with nuts and washers. Note: Use only bolts, nuts, and washers provided with crane. Do not substitute and do not reuse bolts that have been previously torqued.
9. Install master cutoff switch bracket. Line up bracket with the two rear bolts so that the bracket is along the far side of the crane compartment. Install the master cutoff switch to the bracket and set to "OFF" position.
10. Tighten the 5/8-11 Grade 8 bolts in a criss-cross pattern, alternating until torqued to 180 ft-lbs (zinc plated).
11. If crane is being installed on a service or utility body, seal around all holes and bolts with silicone or equivalent sealer. Also seal around crane mounting plate.
12. Locate, attach, and adjust a boom support to contact the main boom behind the hook catch.
13. Attach the 12" power cord between the crane's quill to either terminal of the master cutoff switch. Connect the 25ft power cord to the other terminal of the master cutoff switch then route the cord along the vehicle's frame rail to the vehicle's battery. Care must be taken so that the power cable is not positioned against burrs, sharp edges or anything that would chafe or cut the cable insulation. The cable should be secured to the frame using body clips or wire ties. Use rubber grommets when cable passes through bulkheads.
14. Cut cable to the minimum required length and connect it to the positive post of the vehicle's battery with the appropriate lug or clamp connection.
15. If the vehicle's negative ground cable is grounded only to the vehicle's engine, then install a second ground cable from the negative post of the battery to the vehicle's frame.
16. The vehicle should be equipped with a minimum 125-amp alternator, but a larger capacity is highly recommended. Alternator performance is significantly affected by vehicle RPM and temperature. At standard truck idle speeds, the alternator output can be as low as half of rated capacity.
17. The vehicle should be running during crane operation, and it is recommended that it run at an elevated idle.
18. A 250-amp resettable circuit breaker is recommended for all crane installations (not included) to protect the battery in the event of accidental grounding of the power cable.
19. A stability test is required per OSHA 1910.180(c)(1) to determine the load rating of the completed vehicle.

BATTERY

Adequate battery power is a necessity for satisfactory crane operation. Most original equipment vehicle batteries are designed for relatively light service of vehicle operation.

Normal operation of the crane should not require a second battery. However, on vehicles with longer distances between battery and crane, or if heavy or extended periods of operation are anticipated, a second 12 volt battery can be installed to the vehicle system in order to increase available capacity. If a second battery is used, it should be connected to the first battery in parallel; positive-to-positive and negative-to-negative.

The vehicle charging system should be functioning properly. The battery charging system should supply a minimum of 13 volts DC at the crane with the vehicle engine running. The voltage should not drop below 9 volts when any function of the crane is actuated.

It should also be noted that the performance of the vehicle's alternator drops significantly at low idle speeds. At standard truck idle speeds, the alternator output can be as low as half of the rated capacity. If crane performance or duty cycle is inadequate, consider running the vehicle at an elevated idle during crane operation.

GROUNDING

Proper and adequate grounding of the crane is necessary to prevent poor performance or malfunction. The 3200 Series cranes are grounded through a #2 gauge cable fastened to the bottom of the base quill. A good ground must be established between the crane's base and the vehicle battery. For service or utility body mounting, this grounding typically goes from the crane to the service or utility body, and then to the vehicle frame. If the body is mounted to the truck on non-metallic runners, or rubber mounts, a # 2 gauge ground cable must be added between the body and the chassis frame.

The vehicle battery, and second battery if used, must be grounded directly to the chassis frame. If the vehicle battery is only grounded to the engine block, a second # 2 gauge minimum ground cable must be added from the battery to the chassis frame.

Maintain a regular schedule to ensure that the battery remains in good working condition. Clean all connections, check electrolyte levels, check for loose belts and make sure that your vehicle charging system is operating properly.

WARNING:

1. **FEDERAL LAW (49 CFR PART 571) REQUIRES THAT THE FINAL STAGE MANUFACTURER OF A VEHICLE CERTIFY THAT THE VEHICLE COMPLIES WITH ALL APPLICABLE REGULATIONS. ANY MODIFICATIONS OF THE VEHICLE PRIOR TO THE FINAL STAGE ARE ALSO CONSIDERED INTERMEDIATE STAGE MANUFACTURING AND MUST BE CERTIFIED AS TO COMPLIANCE. THE INSTALLER IS RESPONSIBLE FOR COMPLIANCE WITH ALL APPLICABLE FEDERAL AND STATE REGULATIONS AND REQUIRED TO CERTIFY THAT THE VEHICLE IS IN COMPLIANCE.**
2. **THE INSTALLER OF THE CRANE IS RESPONSIBLE TO COMPLY WITH THE OSHA TRUCK CRANE STABILITY REQUIREMENTS AS SPECIFIED BY 29 CFR PART 1910.180(c)(i).**

OPERATING INSTRUCTIONS (Page 1 of 3)

1. Do not operate this crane unless you have thoroughly read and understand the information in this manual.
2. Cranes shall be operated only by the following qualified personnel, and crane operator certification per OSHA 29 CFR Part 1926.1427-1430. Training and certification is available from local and national certifiers:
 - a. Designated persons
 - b. Trainees under the direct supervision of a designated person
 - c. Inspectors, maintenance and test personnel (when it is necessary in the performance of their duty)
3. No one other than the personnel specified in (2) above shall enter the crane's operating area, with the exception of persons such as supervisors, signal persons, and those specific persons authorized by supervisors whose duties require them to do so, and then only in the performance of their duties and with the knowledge of the operator or other appointed persons.
4. The operator shall be familiar with the equipment and its proper care. If adjustments or repairs are necessary, the operator shall promptly report this to an appointed person, and notify the next operator.
5. The operator at the start of each shift shall test all controls. If any controls do not operate properly, they shall be adjusted or repaired before operations are begun.
6. Seek the best possible work site for the operation when parking the crane-mounted vehicle. The parking location should be firm, dry and level ground or pavement, which can adequately reach the load by the rated capacity of the crane.
7. The crane-mounted vehicle shall not be parked on uneven, rocky or muddy terrain, steep grades, or locations with overhead obstructions.
8. Fully extend the outrigger or jackleg to provide firm support and keep the crane-mounted vehicle as level as possible during the operation. When operating on soft terrain use wider pads or boards under the outrigger feet. Blocking under the outrigger feet shall be of sufficient strength to prevent crushing, bending, or shear failure.
9. After the vehicle has been properly positioned, engage the emergency brake and start the engine.
10. Vehicle should be running during all crane operations, and it is recommended that it run at an elevated idle.
11. Turn the master cutoff switch to the "ON" position to provide power to the crane.
12. Detaching the crane hook from the hook catch can be accomplished by elevating the boom and then lowering the winch. The hook will slide off the catch. Confirm the area for the released, swinging hook.
13. Always boom up to clear the boom support and truck before you rotate or extend boom to desired position.
14. When operating near electric power lines, Figure 1 and Table 1 summarize the minimum clearance requirements wherein no part of the crane or load may enter the danger zone. Refer to OSHA 29 CFR Part 1926.1408 for the complete regulation. For example, with power lines at 50 kV or below, the minimum clearance between the lines and any part of the crane or load (including handling appendages) shall be 10 ft.
15. Caution shall be exercised when working near overhead power lines because they can move horizontally or vertically due to wind, moving the danger zone to a new position.
16. While in transit with no load and boom lowered, the minimum clearances are also summarized in Table 1. Refer to OSHA 29 CFR 1926.1411 for the complete regulation.
17. The crane is now in operating position and ready for handling the load.
18. No crane shall be loaded beyond the specifications of the load rated chart.

OPERATING INSTRUCTIONS (Page 2 of 3)

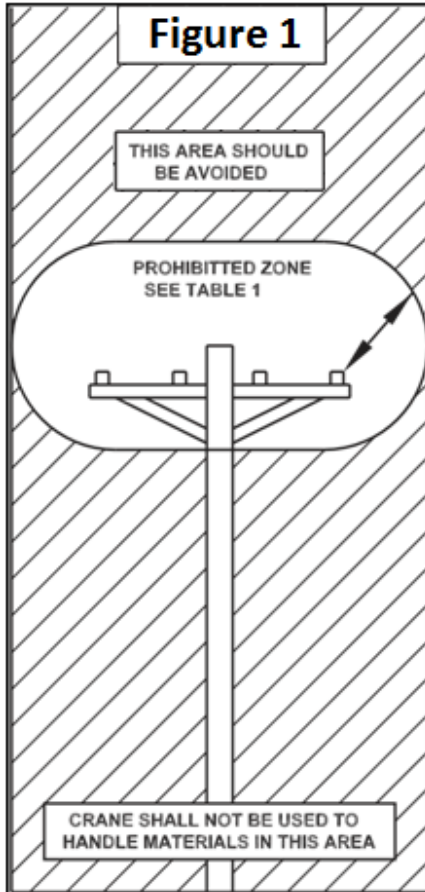

Table 1	
Normal Voltage, kV (Phase to Phase)	Minimum Required Clearance feet (meters)
Operation near High Voltage Power Line	
Up to 50	10 (3.05)
Over 50 to 200	15 (4.57)
Over 200 to 350	20 (6.10)
Over 350 to 500	25 (7.62)
Over 500 to 750	35 (10.67)
Over 750 to 1000	45 (13.72)
Operation in Transit With No Load and Boom Lowered	
Up to 0.75	4 (1.22)
Over 0.75 to 50	6 (1.83)
Over 50 to 350	10 (3.05)
Over 345 to 750	16 (4.88)
Over 750 to 1000	20 (6.10)

19. The load to be lifted is to be within the rated capacity of the crane (refer to the crane load capacity chart).
20. When loads, which are not accurately known, are to be lifted, the person responsible for the job lift shall ascertain that the weight of the load does not exceed the crane ratings at the maximum radius at which the load is to be handled.
21. The hoist rope shall not be wrapped around the load.
22. The load shall be attached to the hook by means of slings or other devices of sufficient capacity.
23. The operator shall not leave the controls while the load is suspended.
24. No person should be permitted to stand or pass under a suspended load.
25. Before starting to lift, the following conditions should be noted:
 - a. The hoist rope shall not be kinked.
 - b. Part lines shall not be twisted around each other.
 - c. The hook shall be brought over the load in such a manner as to minimize swinging.
 - d. The effect of ambient wind on the load and on crane stability.
26. The person directing the lift shall see that:
 - a. The crane is level and, where necessary, blocked.
 - b. The load is well secured and balanced in the sling or lifting device before it is lifted more than a few inches.
 - c. The lift and swing path is clear of obstructions.

OPERATING INSTRUCTIONS (Page 3 of 3)

27. During lifting operations, care shall be taken that:
 - a. There is no sudden acceleration or deceleration of the moving load.
 - b. Load, boom, or other parts of the machine do not contact any obstruction.
28. Side loading of boom shall be limited to freely suspended loads. Crane shall not be used for dragging loads sideways.
29. The operator should never carry loads over people.
30. Neither the load nor boom shall be lowered below the point where less than five full wraps of rope remain on the winch drum.
31. When rotating the crane, sudden starts and stops shall be avoided. Rotating speed shall be such that the load does not swing out beyond the radius at which it can be controlled. A tag or restraint line should be used during rotation to control the load.
32. Personnel shall not be permitted to ride the bare hook or a load of material suspended from the hook.
33. Do not move the vehicle when the crane is being used.
34. The crane shall be in stowed position before traveling.
35. Make sure the remote control is properly stored in a dry area.

INSPECTION & MAINTENANCE SCHEDULE

COMPONENT	DAILY	WEEKLY	MONTHLY	EVERY 3 MONTHS	YEARLY	NOTES
Motor Brushes				X		Check
Cable Drum	X					Make sure the cable is wound evenly on the drum
Cable	X					Check for cut or broken strands, kinking etcetera *
Load Hook	X					Check for any cracks or deformation of the hook or latch
Sheaves and Bearings				X		Inspect for any damage and add grease to bearings. Make sure the sheaves turn freely
Rotational Bearing				X Or more often under severe conditions		Add grease to the bearing
Base Mounting Bolts & Other Bolts		X				Check the bolt torque for the four mounting bolts and tighten other bolts as required
Hydraulic Hoses	X					Inspect for any damage or leakage at fittings
Hydraulic Fluid	X					Check fluid level at the reservoir before each shift
Hydraulic Reservoir					X	Drain, flush, and refill with hydraulic fluid
Hydraulic Oil Filter					X	Replace Spin-On Oil Filter
Boom Wear Pads				X		Inspect pads and replace as required
Boom Pivots				X Or more often under severe conditions		Add grease to fittings **

* To extend the life of cable, clean it periodically with a wire brush and lubricate it lightly with oil.

** All other bushings used are made of brass impregnated with an oil and graphite compound and require no maintenance. Other parts may be lubricated with a few drops of oil as needed.

LUBRICATION & HYDRAULIC FLUID SPECIFICATIONS

1. Rotational Bearings: Mobil grease CM-S or equivalent
2. Hydraulic Fluid: Mobil DTE26 or equivalent premium grade hydraulic fluid

TURRET ASSEMBLY (P/N 43793) (Page 1 of 6)

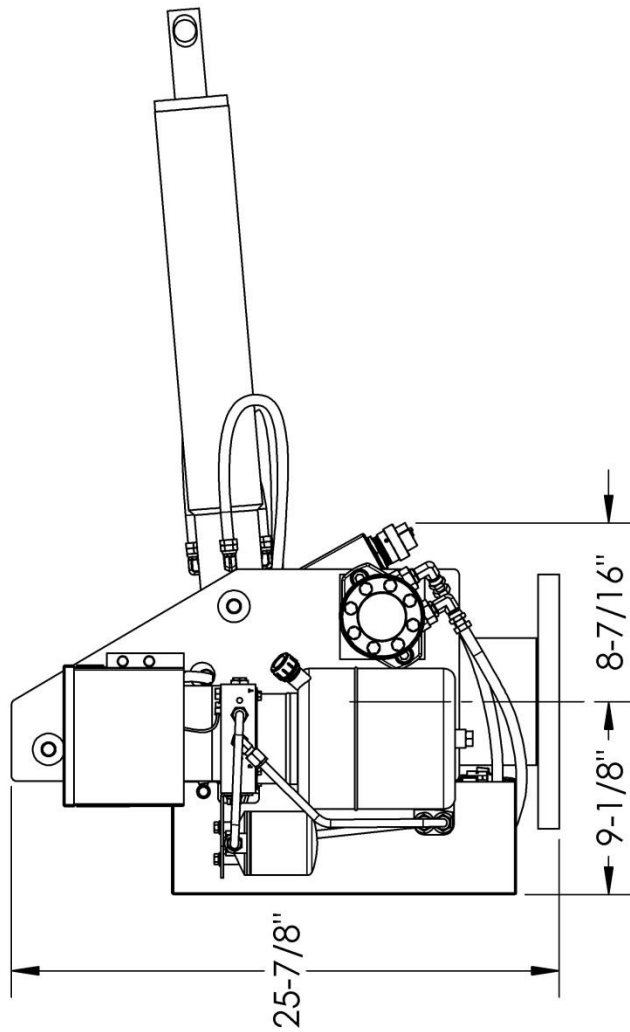
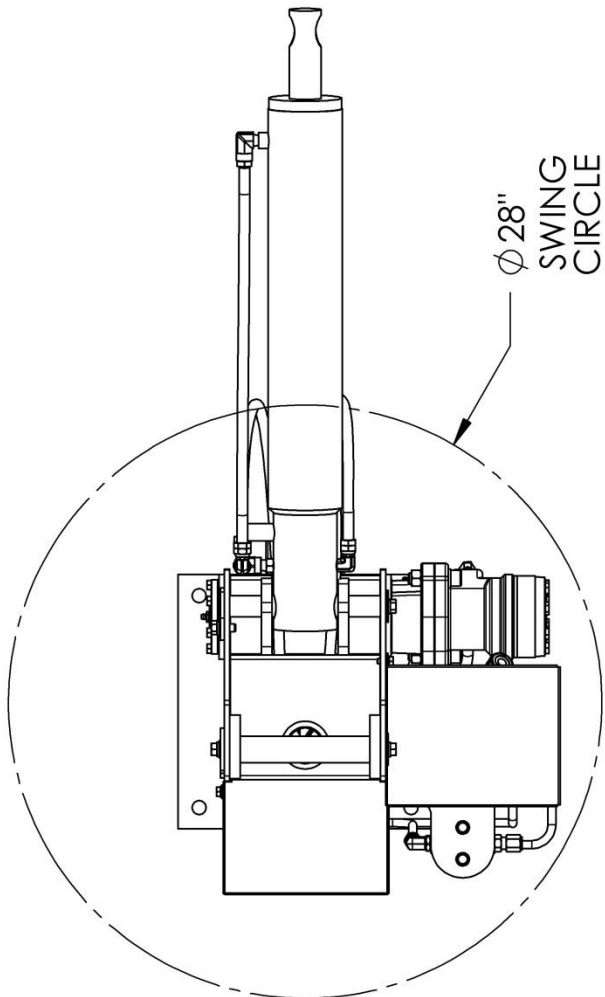
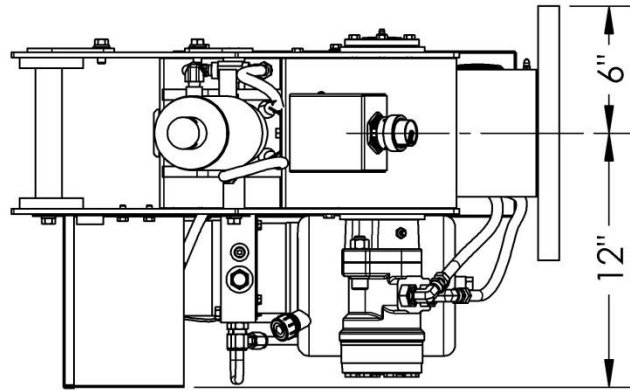

TURRET ASSEMBLY (P/N 43793) (Page 2 of 6)

ITEM	PART #	QTY	DESCRIPTION	ITEM	PART #	QTY	DESCRIPTION
1	03030	2	WASHER-LOCK 1/2	54	43761	1	SPACER-3200 TUR ROT BRG
2	07702	1	BUSH-0.25 0.38 0.38 FLNG	55	43762	1	COVER-TURRET REAR 3200
3	07843	1	NUT-HX 1/4-20	56	43763	1	SHAFT-08 WORM 3200 ROT
4	07850	1	NUT-HX 3/8-16	57	43767	1	BRKT-ROD ELEC 3200
5	07858	2	NUT-HX 1/2-13 G8	58	43774	1	BRKT-3200 HOSE RING
6	07882	10	WASHER-LOCK 1/4	59	43775	4	FITTING-.56MS .25FPS45
7	07885	4	WASHER-FLT 3/8 N	60	43776	1	GROMMET-1.63 ID 2.00 OD
8	07886	8	WASHER-LOCK 3/8	61	43779	2	HOSE-HYD 0.25D .25MP 17.2L
9	07898	1	BOLT-HX 1/4-20X3/4	62	43780	2	HOSE-HYD 0.25D .25MP 34.0L
10	14938	1	SCRW-STSKT 3/8CX1.50 DOG	63	43781	2	HOSE-HYD 0.25D .25MP 50.0L
11	40006	1	KEY-08 WORM 0.18 2.37	64	43799	2	FITTING-.56MS .25FP 90
12	40034	1	WORM-08 36:1 LH	65	43801	1	FITTING-.25MP .25FPS ORF
13	40041	1	GASKET-08 HYD FLANGE	66	43802	1	PUMP ASY-12V HYD 3200
14	40078	1	BEARING HOLDER	67	43804	1	WIRE ASY-#02 13.5 QUILL
15	40080	2	FITTING-GREASE .25NF	68	43816	1	TIE-CABLE 03.9L BLK NYL
16	40156	2	BEARING-CONE 08 0.87ID	69	43831	2	WASHER-FLT 3/8 FENDER
17	40157	2	BEARING-CUP 08 2.12OD	70	43833	2	SCRW-CPSKT 3/8-16X7/8
18	40341	1	MOTOR-HYD DS160 151-2305	71	43916	2	WASHER-LOCK INTERNAL #4
19	40605	1	SCREW-STSKT 0.37 0.4 OVL	72	43999	1	TERMINAL-14GA #6 FORK
20	40900	15	BOLT-HX 1/4-20X9/16 (40900)	73	44014	1	LOOM-SPIRAL CUT 1/2" BLK
21	40911	6	BOLT-HX 3/8-16X7/8	74	44231	1	HOSE-HYD 0.25D .25MP 20.0L
22	40986	10	WASHER-FLT 1/4 N	75	44232	1	NIPPLE-HEX .25MP .25MP
23	40992	6	WASHER-LOCK HI COLLAR .2	76	44234	1	BRKT-3200 ELE ASY MTG
24	41016	6	SCRW-CPSKT 1/4-20X1 3/4	77	44239	1	CONTACTOR-3200 WARN
25	41095	6	BOLT-HX 1/4-20X7/8	78	44343	1	COVER-PUMP 3200 CRANE
26	41124	1	PIN-SPRNG 0.12 1.00	79	44457	0.75	WIRE-#18 BULK ORG FEET
27	41155	1	TERMINAL-18GA #10 RING	80	44719	2	NUT-HX #6-32 NYLK
28	41967	2	GASKET-08 BRG COVER	81	44812	2	WIRE ASY-#04 14.0 GRND
29	42020	2	SCRW-CPSKT 1/2-13X2	82	44926	1	ADAPTER-HYD 08 W/G FITTG
30	43201	1	CONNECTOR-CABLE PANEL	83	44927	2	SEAL CUP-WORNSHAFT 08
31	43297	2	BEARING-CONE 3.375X5.375	84	44928	2	SPACER-WORMSHAFT 08
32	43298	2	BEARING-CUP 3.375X5.375	85	44930	1	PLUG-08 W/GREASE FITTING
33	43305	1	BASE ASY-3200 TURRET	86	44949	1	HARNESS-4000
34	43327	1	GEAR-3200 36:1 LH	87	45176	1	MANIFOLD PKG-3200ERX V2
35	43336	1	ROD-ELEC TURRET 3200	88	45182	2	FITTING-.56MS .38TBC 90
36	43346	1	PAD-MTG CONNECTING ROD	89	45184	1	TUBE-3200 HYD MAN/FLTR
37	43360	8	SCREW - SHLDR - 0.5" x 1.5"	90	45185	1	TUBE-3200 HYD FLTR/PUMP
38	43362	2	SCRW-PAN #4-40X3/4	91	45186	1	TUBE-3200 HYD PRESSURE
39	43363	2	NUT-HX #4-40	92	45189	1	BRKT-3200 FILTER
40	43370	4	FITTING-.56MS .37TB ST	93	45190	1	FILTER HEAD-HYD BF-06-0
41	43371	2	FITG-06MOR-04FPS 90	94	45191	1	FILTER-HYD BE-10-18
42	43374	1	FITTING-.25FP TEE	95	45192	2	SPACER-3200 MANIFOLD
43	43376	4	FITTING-.25MP .25FPS 90	96	45204	1	SWITCH-PLUNGER SPDT BZ
44	43379	1	FITTING-.25MP .25FP 90	97	45205	2	SCRW-PAN #6-32X1
45	43425	4	NUT-HEX .250NC FLEX	98	45238	1	WIRE ASY-CONTACTOR GRND
46	43452	1	WIRE ASY-#02 18.5 PUMP	99	45239	1	BRKT-3200 SWITCH MTG
47	43469	2	BOLT-HX 5/16-18X3-3/4	100	45272	1	CAP-DUST HDC36-18
48	43511	1	SCRW-PHPHL #6-32 0.4 TF	101	45273	2	FITG-10MOR-06FOR ST
49	43704	1	TURRET ASY- 3200 WELDMENT	102	45275	1	SCRW-HX 1/4CX2-1/4 BRASS
50	43715	1	CYL-HYD 3.00B 14.50S	103	45401	1	WIRE ASY-#02 16.0 GRND
51	43738	2	WIRE ASY-#02 36.0 WINCH	104	45407	1	SPRING-0.344OD 1.0FL SS
52	43752	1	PIN-W/KPR 1.00 7.69 2.00	105	45408	1	GROMMET-FLEXIBLE 1-1/4"ID
53	43756	1	PIN-W/KPR 1.25 7.69 2.50				

TURRET ASSEMBLY (P/N 43793) (Page 3 of 6)

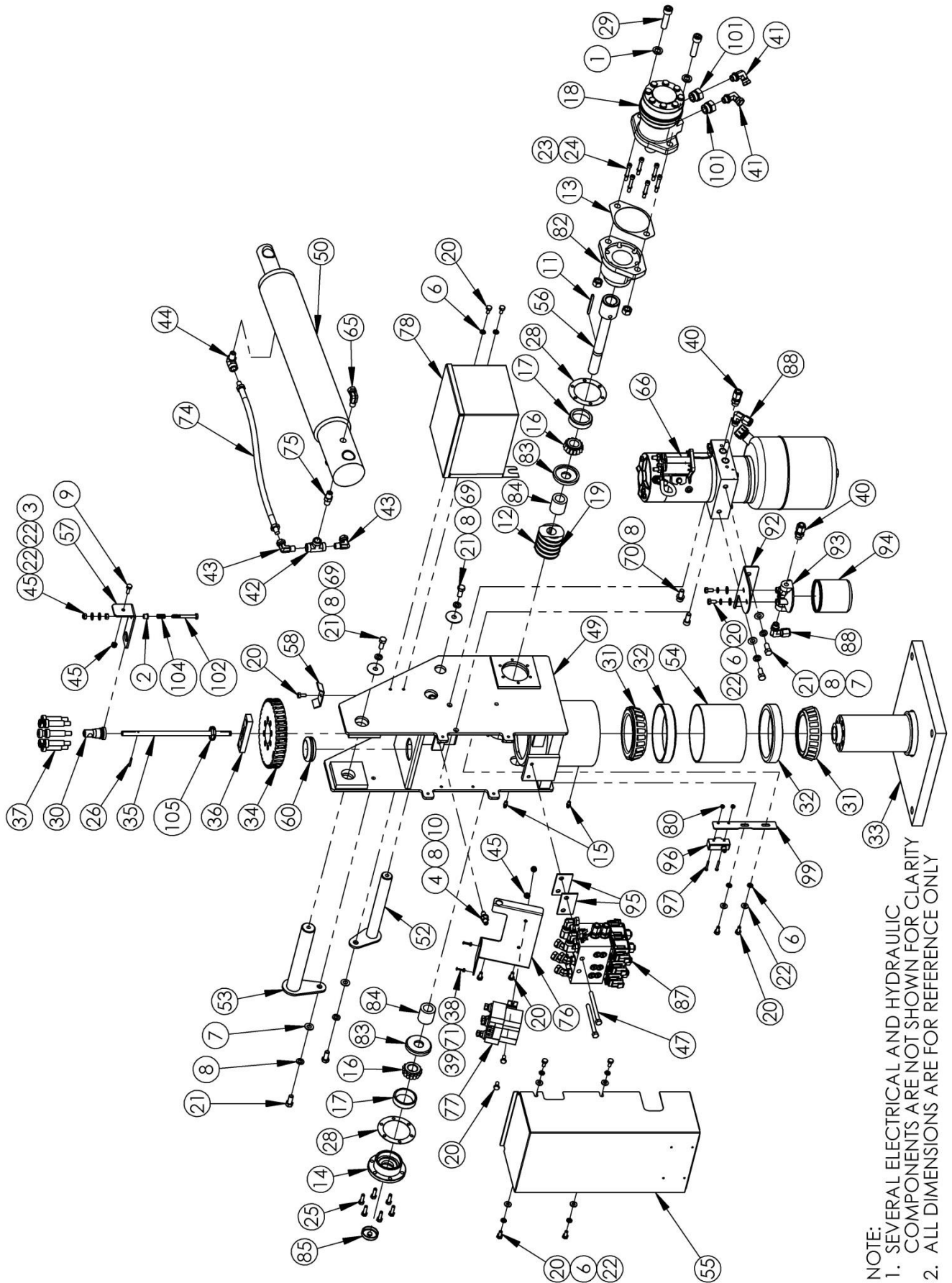

NOTE:
1. SEVERAL ELECTRICAL AND HYDRAULIC COMPONENTS ARE NOT SHOWN FOR CLARITY
2. ALL DIMENSIONS ARE FOR REFERENCE ONLY

TURRET ASSEMBLY (P/N 43793) (Page 4 of 6)

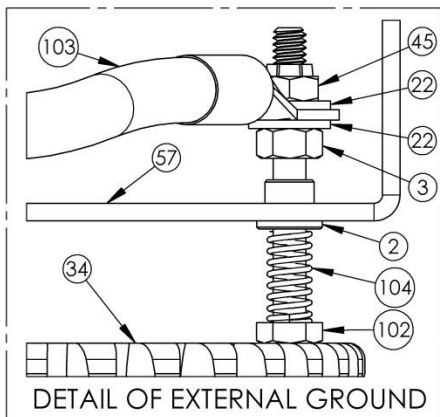
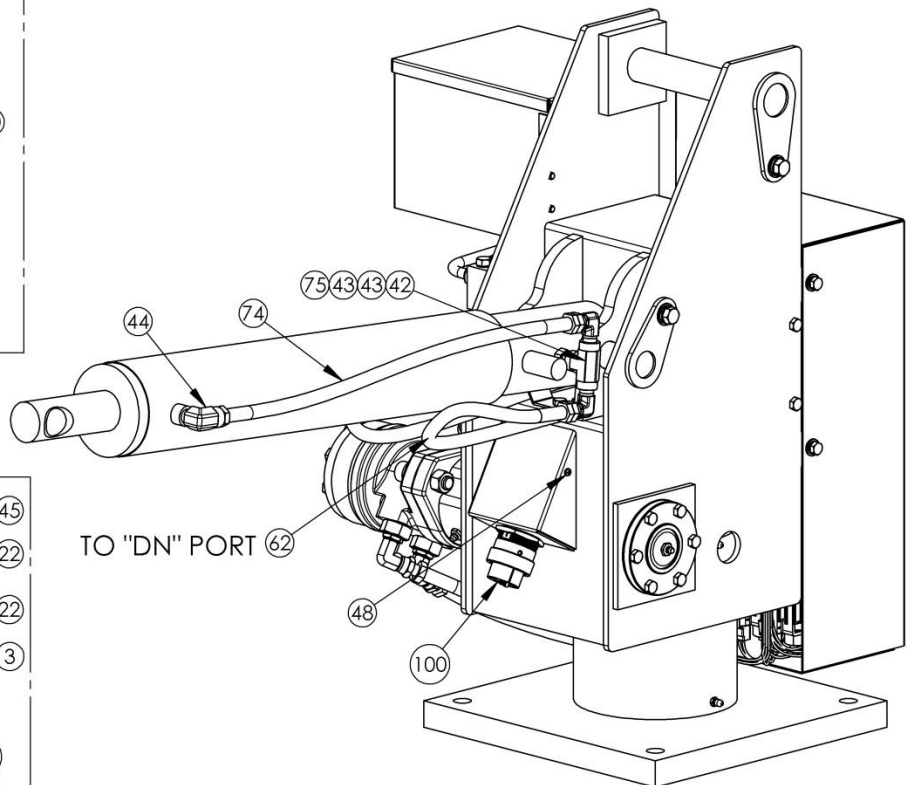
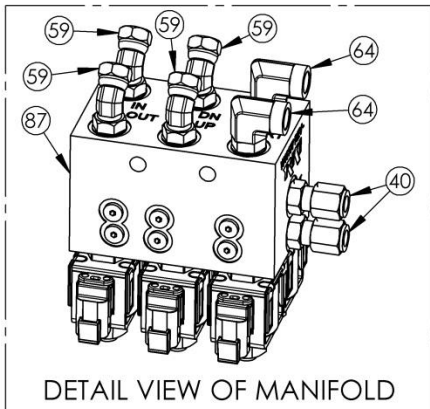
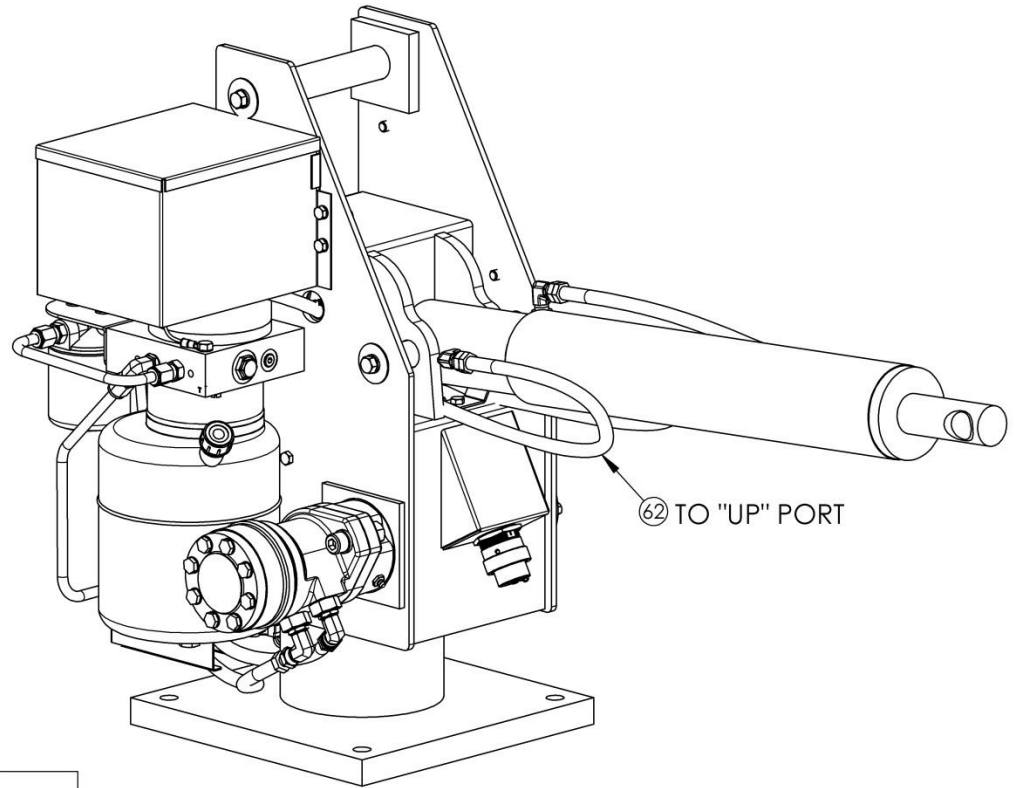

TURRET ASSEMBLY (P/N 43793) (Page 5 of 6)

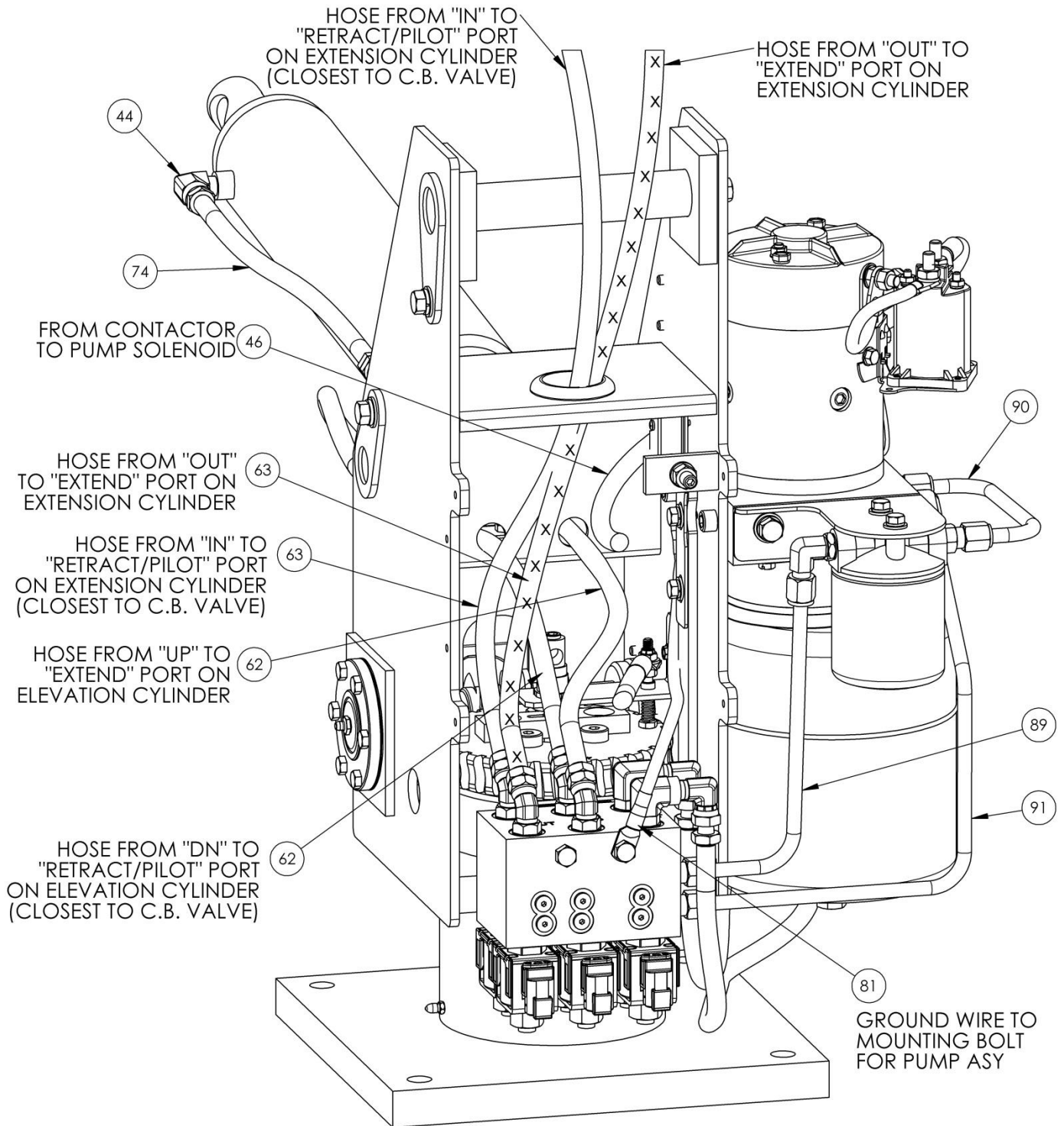

TURRET ASSEMBLY (P/N 43793) (Page 6 of 6)

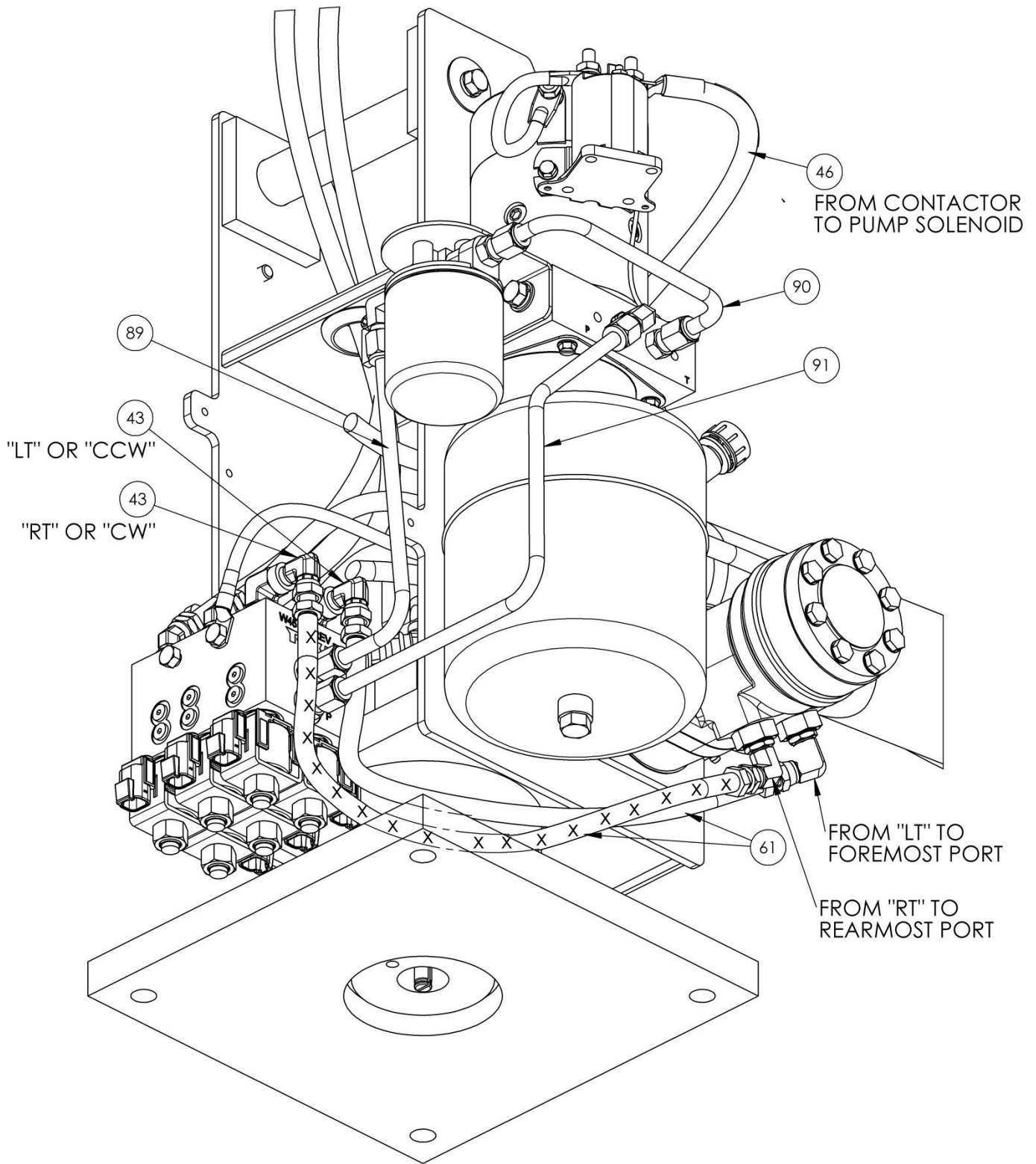

BOOM ASSEMBLY (P/N 43784) (Page 1 of 2)

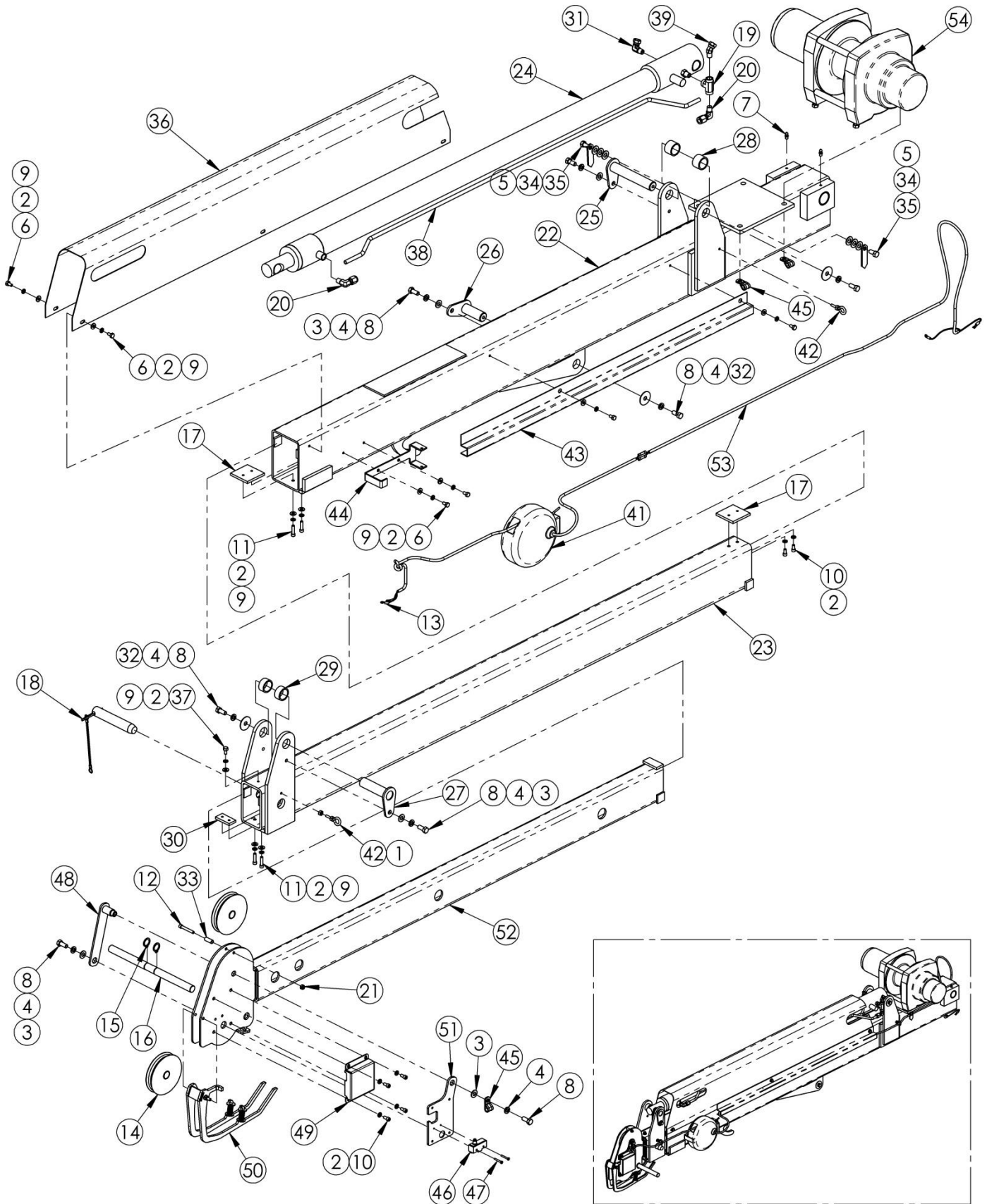

BOOM ASSEMBLY (P/N 43784) (Page 2 of 2)

ITEM	PART #	QTY	DESCRIPTION	ITEM	PART #	QTY	DESCRIPTION
1	07843	1	NUT-HX 1/4-20	28	43758	2	SPACER-3200 EXT CYL HEAD
2	07882	19	WASHER-LOCK 1/4	29	43759	2	SPACER-3200 EXT CYL ROD
3	07885	5	WASHER-FLT 3/8 N	30	43783	1	SPACER-3200 EXT BOOM
4	07886	8	WASHER-LOCK 3/8	31	43801	1	FITTG-.25MP .25FPS ORF
5	07887	6	WASHER-FLT 7/16 N	32	43831	3	WASHER-FLT 3/8 FENDER
6	07916	8	BOLT-HX 1/4-20X1/2	33	43909	1	SPACER-TUBE 3/8OD 15/16"
7	40080	2	FITTING-GREASE .25NF	34	44009	2	POINTER-DEGREE INDICATOR
8	40911	8	BOLT-HX 3/8-16X7/8	35	44031	2	BOLT-HX 3/8-16X3/4 LK
9	40986	13	WASHER-FLT 1/4 N	36	44093	1	COVER-3200ERX EXTEND CYL
10	41013	6	SCRW-CPSKT 1/4-20X1/2	37	44102	1	SCREW-CPHEX 0.25X.50 THD
11	41015	4	SCRW-CPSKT 1/4-20X1	38	44126	1	TUBE-3200 HYD CYL EXT
12	41016	1	SCRW-CPSKT 1/4-20X1 3/4	39	44184	1	FITTING-.25MP .25FPS45
13	41155	2	TERMINAL-18GA #10 RING	40	44232	1	NIPPLE-HEX .25MP .25MP
14	43041	2	PULLEY-4.0 OD .75BORE	41	44248	1	REEL-CORD 20FT 18/3
15	43139	2	RING-RTNG EXT 0.750 1P	42	44249	2	EYE BOLT-1/4-20X1 W/ NUT
16	43166	1	PIN-GRVD. 0.75 1.37	43	44258	1	CORD GUIDE-3200 CRANE
17	43331	2	SPACER-BOOM 3200	44	44640	1	BRACKET - CABLE REEL
18	43345	1	PIN-QUICK 1.00 4.00 W/L	45	44798	3	CLAMP-LOOM 3/8 MTG
19	43374	1	FITTG-.25FP TEE	46	45204	1	SWITCH-PLUNGER SPDT BZ
20	43375	2	FITTG-.25MP .37TBC 90	47	45205	2	SCRW-PAN #6-32X1
21	43425	1	NUT-HEX .250NC FLEX	48	45209	1	PIN-W/KPR 0.75 1.13 5.75
22	43705	1	BOOM ASY-3200ERX MAIN	49	45219	1	COVER-CRANE A2B
23	43706	1	BOOM ASY-3200ERX IMDT	50	45220	1	RAIL PKG-CRANE A2B
24	43708	1	CYL-HYD 2.00B 48.00S	51	45233	1	PIN-W/KPR A2B 3200
25	43754	1	PIN-W/KPR 1.00 5.81 2.00	52	45237	1	BOOM-3200 EXT
26	43753	1	PIN-W/KPR 1.00 2.69 2.00	53	45241	1	WIRE ASY-CORD REEL EXT
27	43755	1	PIN-W/KPR 1.00 3.81 2.00	54	45243	1	WINCH-WARN DC2000LF

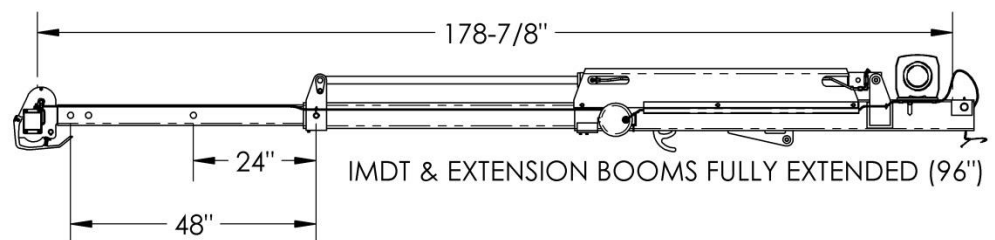
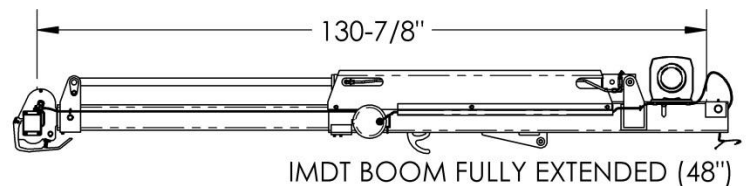
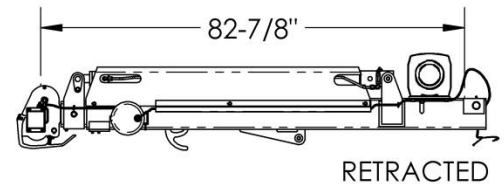

WIRING SCHEMATIC

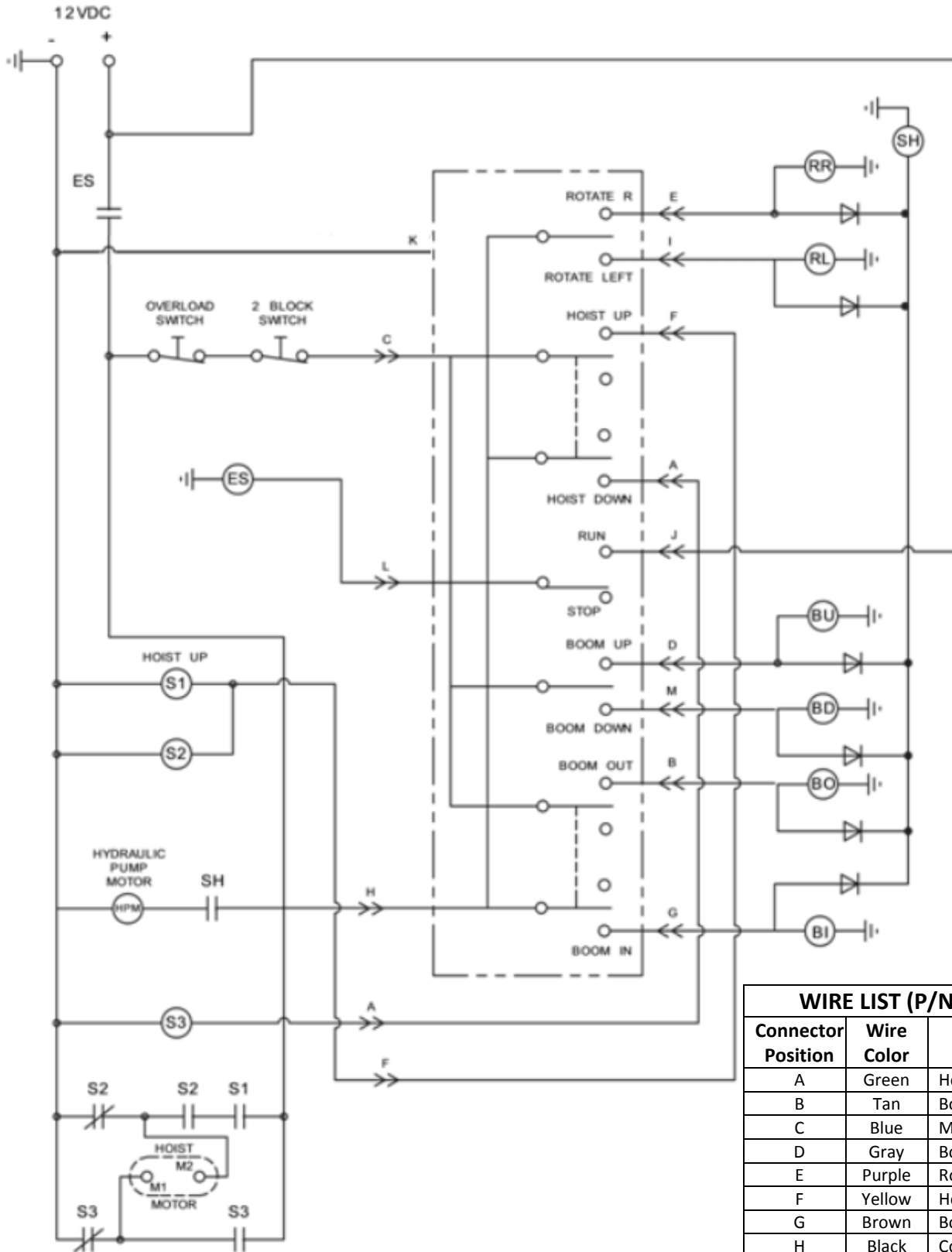

WIRE LIST (P/N 44949)		
Connector Position	Wire Color	Usage
A	Green	Hoist Down
B	Tan	Boom Out (BO)
C	Blue	Microswitch
D	Gray	Boom Up (BU)
E	Purple	Rotate Right (RR)
F	Yellow	Hoist Up
G	Brown	Boom In (BI)
H	Black	Common (+)
I	Red	Rotate Left (RL)
J	Orange	Emergency Stop
K	No wire	Ground
L	Pink	Emergency Stop
M	White	Boom Down (BD)

ELECTRICAL LAYOUT (W0180) (Page 1 of 2)

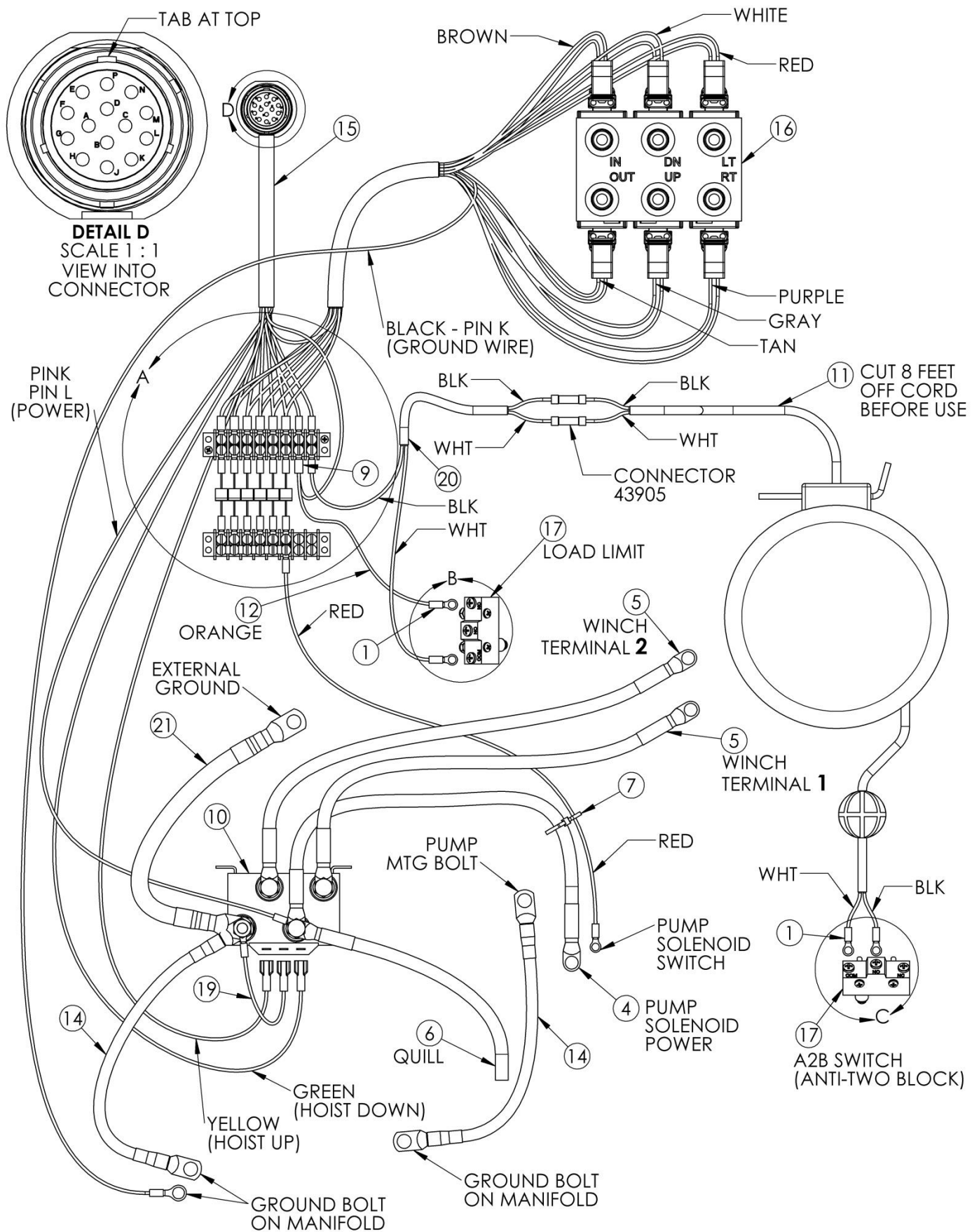

ELECTRICAL LAYOUT (W0180) (Page 2 of 2)

ITEM	PART #	QTY	DESCRIPTION
1	41155	3	TERMINAL-18GA #10 RING
2	43362	2	SCRW-PAN #4-40X3/4
3	43363	2	NUT-HX #4-40
4	43452	1	WIRE ASY-#02 18.5 PUMP
5	43738	2	WIRE ASY-#02 36.0 BLK
6	43804	1	WIRE ASY-#02 13.5 QUILL
7	43816	1	TIE-CABLE 03.9L BLK NYL
8	43916	2	WASHER-LOCK INTERNAL #4
9	43999	1	TERMINAL-14GA #6 FORK
10	44239	1	CONTACTOR-3200 WARN34440
11	44248	1	REEL-CORD 20FT 18/3
12	44457	0.75	WIRE-#18 BULK ORG FEET
13	44719	2	NUT-HX #6-32 NYLK
14	44812	2	WIRE ASY-#04 14.0 GRND
15	44949	1	HARNESS-ERX 3200/4000
16	45176	1	MANIFOLD PKG-ERX V2
17	45204	2	SWITCH-PLUNGER SPDT BZ
18	45205	4	SCRW-PAN #6-32X1
19	45238	1	WIRE ASY-CONTACTOR GRND
20	45241	1	WIRE ASY-CORD REEL EXT
21	45401	1	WIRE ASY-#02 16.0 GRND

NOTES:

1. TETHERED REMOTE CONTROL, 45366 (STD)
2. WIRELESS REMOTE KIT, 45168 (OPTIONAL)

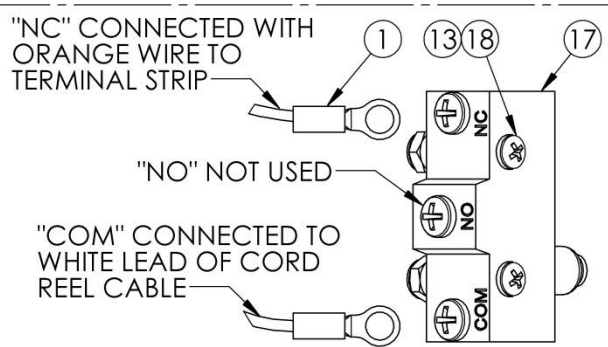

DETAIL B - LOAD LIMIT
SCALE 4 : 5

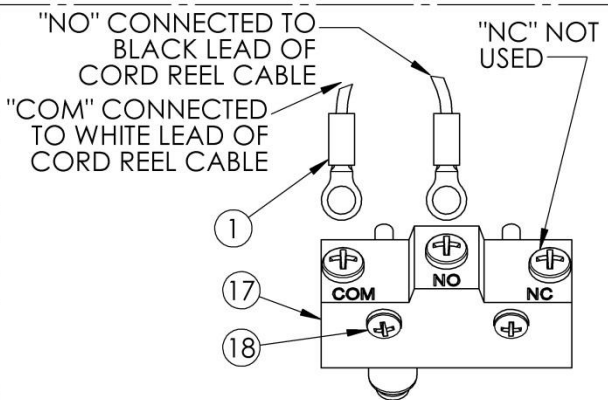

DETAIL C - ANTI TWO-BLOCK
SCALE 4 : 5

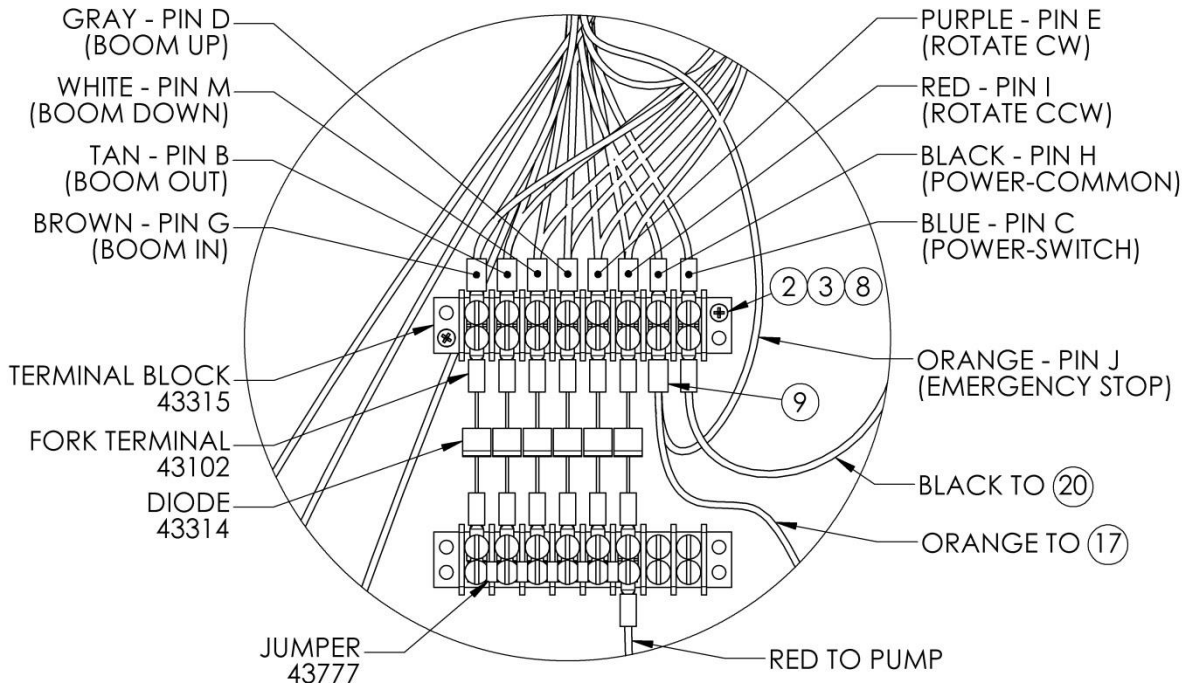

DETAIL A - TERMINAL STRIPS
SCALE 1 : 2

HYDRAULIC LAYOUT (W0186)

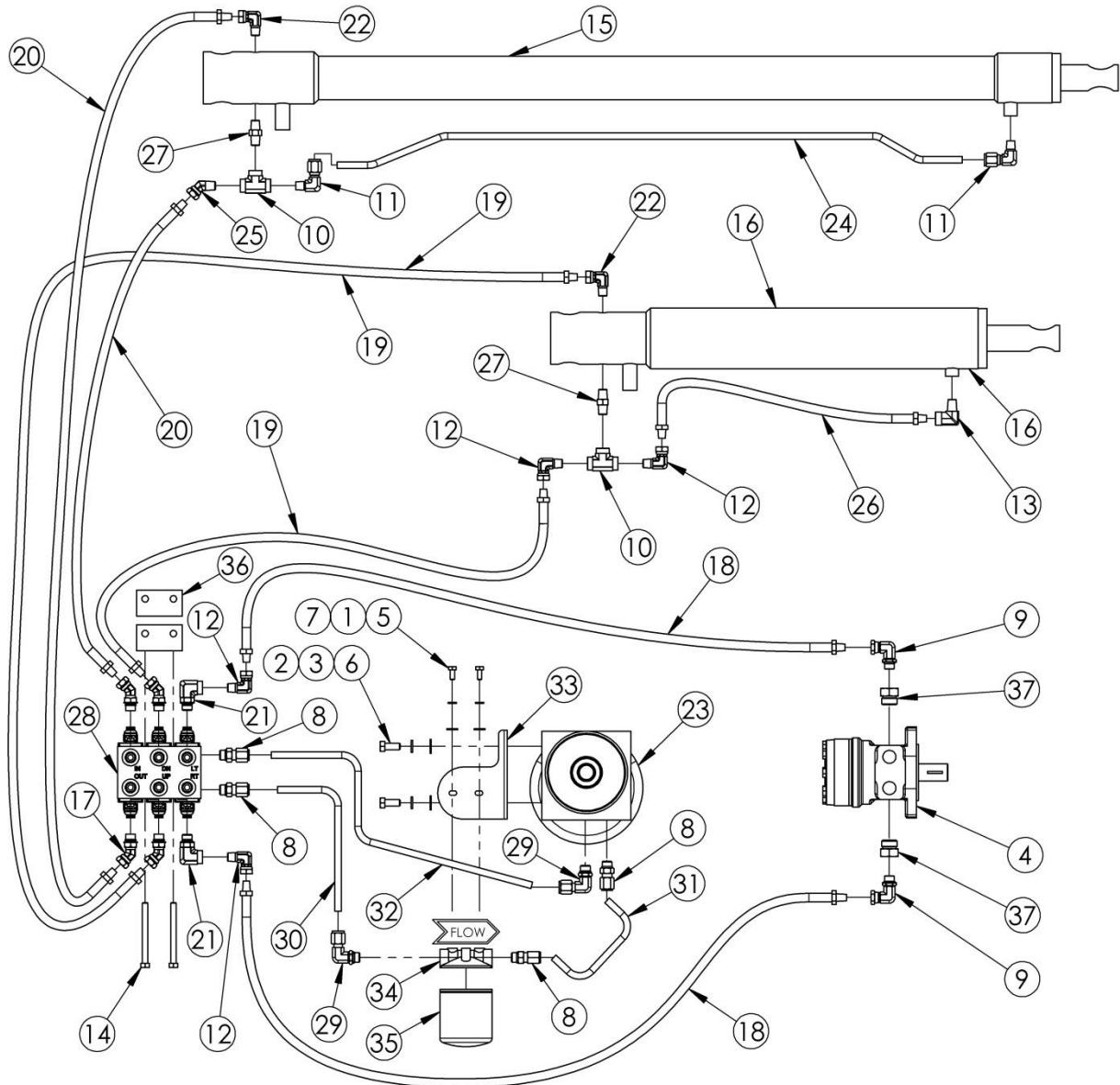

ITEM	PART #	QTY	DESCRIPTION	ITEM	PART #	QTY	DESCRIPTION
1	07882	2	WASHER-LOCK 1/4	20	43781	2	HOSE-HYD 0.25D .25MP 50.0L
2	07885	2	WASHER-FLT 3/8 N	21	43799	2	FITG-.56MS .25FP 90
3	07886	2	WASHER-LOCK 3/8	22	43801	2	FITG-.25MP .25FPS ORF
4	40341	1	MOTOR-HYD DS160 151-2305	23	43802	1	PUMP ASY-3200 HYD 12V
5	40900	2	BOLT-HX 1/4-20X9/16	24	44126	1	TUBE-3200 HYD CYL EXT
6	40911	2	BOLT-HX 3/8-16X7/8	25	44184	1	FITTING-.25MP .25FPS45
7	40986	2	WASHER-FLT 1/4 N SAE	26	44231	1	HOSE-HYD 0.25D .25MP 20.0L
8	43370	4	FITG-.56MS .37TB ST	27	44232	2	NIPPLE-HEX .25MP .25MP
9	43371	2	FITG-06MOR-04FPS 90	28	45176	1	MANIFOLD PKG-3200ERX V2
10	43374	2	FITG-.25FP TEE	29	45182	2	FITG-.56MS .38TBC 90
11	43375	2	FITG-.25MP .37TBC 90	30	45184	1	TUBE-3200 HYD MAN/FLTR
12	43376	4	FITG-.25MP .25FPS 90	31	45185	1	TUBE-3200 HYD FLTR/PUMP
13	43379	1	FITTING-.25MP .25FP 90	32	45186	1	TUBE-3200 HYD PRESSURE
14	43469	2	BOLT-HX 5/16-18X3-3/4	33	45189	1	BRKT-3200 FILTER
15	43708	1	CYL-HYD 2.00B 48.00S	34	45190	1	FILTER HEAD-HYD BF-06-0
16	43715	1	CYL-HYD 3.00B 14.50S	35	45191	1	FILTER-HYD BE-10-18
17	43775	4	FITTING-.56MS .25FPS45	36	45192	2	SPACER-3200 MANIFOLD
18	43779	2	HOSE-HYD 0.25D .25MP 17.2L	37	45273	2	FITG-10MOR-06FOR ST
19	43780	2	HOSE-HYD 0.25D .25MP 34.0L				

TRAVEL BLOCK ASSEMBLY (P/N 45215)

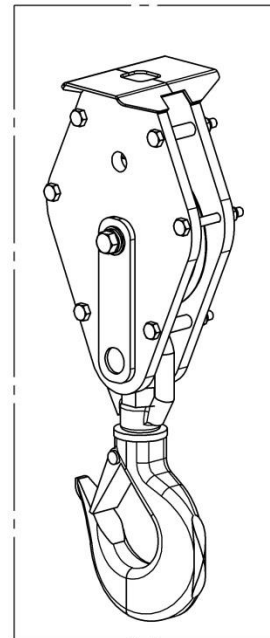
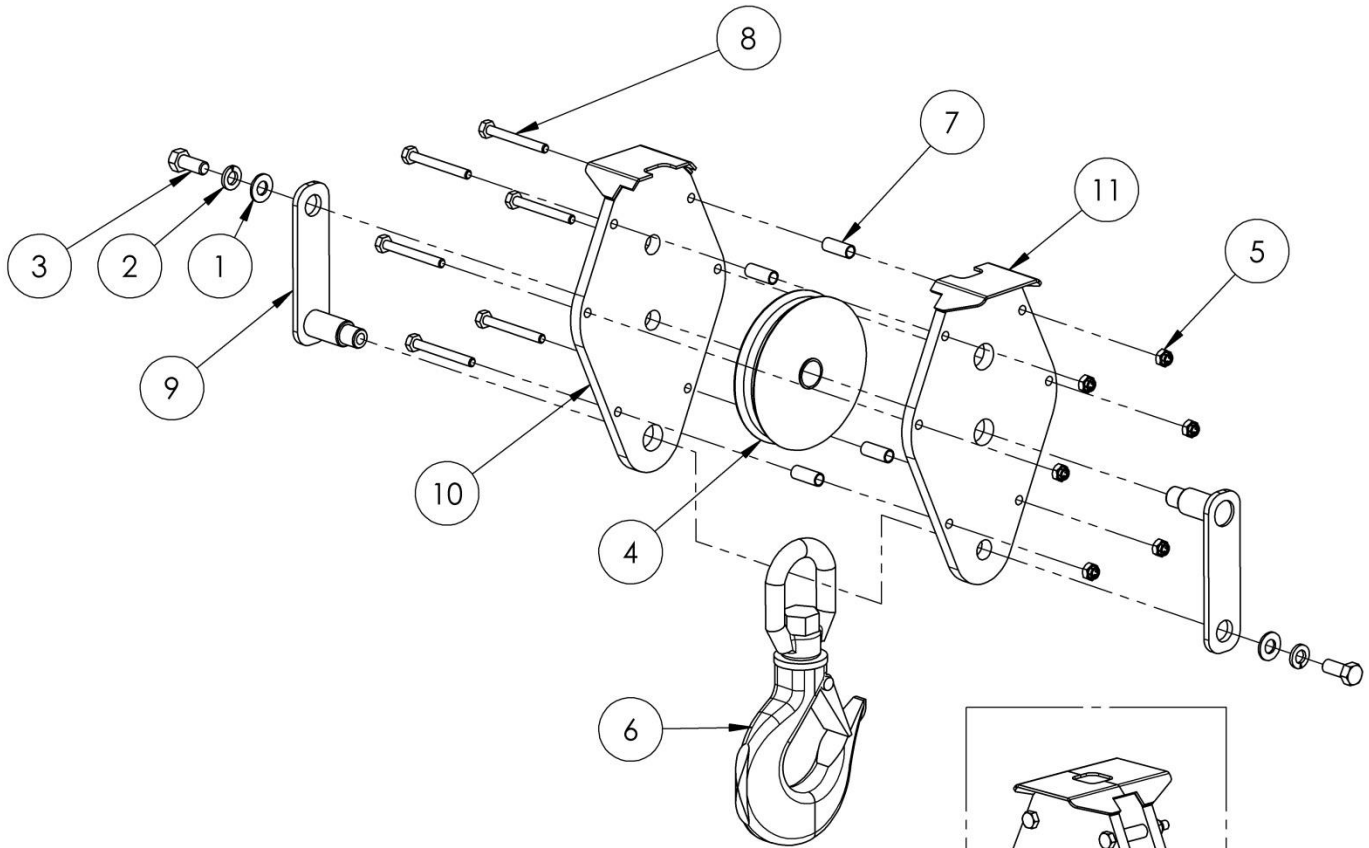

ITEM	PART #	QTY	DESCRIPTION
1	07885	2	WASHER-FLT 3/8 N
2	07886	2	WASHER-LOCK 3/8
3	40911	2	BOLT-HX 3/8-16X7/8
4	43041	1	PULLEY-4.0 OD .75BORE
5	43425	6	NUT-HEX .250NC FLEX
6	43819	1	HOOK-2.0 TON SWIVEL W/L
7	43909	4	SPACER-TUBE 3/8OD 15/16"
8	44002	6	BOLT-HX 1/4-20X2 1/4
9	45212	2	PIN-W/KPR 0.75 1.31 3.50
10	45216L	1	PLATE ASY-TRAV BLOCK LEFT
11	45216R	1	PLATE ASY-TRAV BLOCK RIGHT

ANTI TWO-BLOCK (A2B) SYSTEM

Your RKI crane is equipped with an anti two-block (A2B) system, per OSHA 29 CFR Part 1926.1416(d)(3), to prevent damage from contact between the travel block and the boom tip. If the travel block is allowed to contact the end of the boom, continued operation could result in significant damage to the crane and possibly failure of the wire rope. When the travel block comes in contact with the rail mechanism at the end of the boom, the crane will disable the hoist up, boom out, and boom up/down functions. The other functions, namely hoist down, boom in, and rotation, will operate as normal.

The microswitch located at the end of the boom head and the rail mechanism are pre-set at the RKI factory. No adjustment or resetting is necessary. If either of the two following conditions exists, then the crane requires service:

- When the travel block compresses the rail mechanism and it comes in contact with the boom head, and all the crane functions continue to operate, particularly hoist up and boom out.
- When the travel block is not in contact with the rail mechanism or the boom head, and all crane functions fail to operate, particularly hoist up and boom out.

OVERLOAD SENSOR CALIBRATION

Your RKI crane is equipped with a torque reading load sensor, to prevent overloading. If the crane's load capacity is exceeded, the load sensor deactivates all winch functions except rotation, boom in, and hoist down. Removing the load from the crane or reducing its effective moment will automatically reset the overload sensor, returning full function to the crane. The 3200 crane comes from the RKI factory set for maximum capacity of 3,200 lbs and 10,000 ft-lbs of effective moment. If the load sensor gets out of adjustment or the crane is being intentionally set for a reduced capacity, see the instructions below for recalibration.

The following is the procedure for adjusting the overload sensor:

1. A plunger-type microswitch is located in the upper right section of the crane turret housing. It is fastened to a bracket, which in turn is secured to an upright bar welded to the crane turret base. This microswitch and its position should not need to be adjusted or moved for this procedure.
2. Contacting the plunger of the microswitch is a 3/8-16 dog-point set screw, threaded through a mounting plate attached to the right side of the turret. This set screw is secured with a lock washer and nut.
3. Calibration is accomplished by adjusting the engagement of this set screw with the microswitch plunger.
4. With the crane securely mounted, adjust the boom elevation and extension until the hook is at a position exactly 3 feet from the center of the crane turret (center of rotation). Connect a dynamometer between the hook and a secure attachment point. If you do not have a dynamometer (scale) please see the note below.
5. Slowly raise the hook with the "Hoist Up" switch on the control until the dynamometer reads 3,200 lbs.
6. When the dynamometer reads 3,200 lbs, the load sensor should stop the winch. If the overload sensor is set correctly, and the winch function is disabled, proceed to step 10.
7. If the target load is not achieved, or the winch is still functional, then calibration is made by adjusting the set screw. Loosen the nut that secures the set screw and adjust the set screw. Turning the set screw clockwise (more engagement) increases the load capacity while turning it counterclockwise (less engagement) decreases load capacity. An audible 'click' from the microswitch may help in adjustments.
8. Relieve the load with the "Hoist Down" switch on the control until the dynamometer reads 0 (zero) lbs.
9. Repeat steps 5 through 8 until the desired functionality is achieved.
10. Once calibration is complete, re-tighten the nut securing the set screw to lock its position.

*** NOTE:** If a dynamometer is not available, a known weight at a known radius, whose multiplication equals 10,000 ft-lbs, can be used. Example combinations include 2,000 lbs @ 5ft, and 1,000 lbs @ 10ft.

REPLACEMENT PARTS & ACCESSORIES

It is recommended that repair parts for your crane be obtained from your local RKI distributor. Please note that unauthorized servicing or alteration of your crane will void the warranty.

Each crane is assigned a serial number, which is a nameplate located near the bottom of the rear cover. The serial number can also be found in the owner's manual that is provided with the crane.

Please record your serial number and retain a copy of your invoice for future reference. If your crane should need service, this information will be required.

Below is a partial list of replacement parts and accessories. Please contact your distributor or RKI for additional items:

Part Description	Part Number	Comment
Boom Supports	various	Service Body Boom Supports (BMS1, BMS2, or BMS3)
Bronze Bushing	40005	Main boom pivots
Cord Reel Package	44193	Includes cord reel, micro switches, cable, and hardware
Counterbalance Valve	44344	Hydraulic cylinder C.B. valve (same for both cylinders)
Decal Kit	44357	Includes all decals for crane (ERX model)
Dipstick	44727	Oil Reservoir
Dust Cap	45272	Cover remote socket, with chain
Jacklegs	various	Service Body stabilizing jack legs (JLK2 or JLK3)
Manifold	45177	Hydraulic manifold only (ERX model)
Motor-Hydraulic Pump	45015	Motor only of 43802
Motor-Hoist Winch	44516	Motor only of 45243, 2 post
Mounting Holes	CRKHOLESR2	Pre-lasered holes in Service Body mounting plate
Oil Filter	45191	Spin-On, 10 micron
Oil Reservoir	44998	Reservoir only, includes o-ring and breather
Remote Control, Tethered	45366	21ft tethered remote control with bayonet connector
Remote Control, Wireless	45168	Handheld transmitter, plug-n-play with bayonet connector
#2 SAE Plug	45181	O-Ring Plug for hydraulic manifold
Seal Kit-Boom In/Out Cylinder	45159	Seal kit for 43708 extension cylinder
Seal Kit-Boom Up/Down Cylinder	45160	Seal kit for 43715 elevation cylinder
Solenoid-Hydraulic Pump	45004	Starter solenoid only of 43802 pump
Terminal Boot	41376	Rubber Cap for winch motor terminals
Valve-Hydraulic Solenoid	45178	Cartridge valve only for manifold

TROUBLESHOOTING

Problem	Solution
Crane slowly stops while lifting	Check for weak battery or bad connections
Cranes only operable functions are rotation, boom in, or hoist down	<p>Overload sensor may be set off. Lower load to ground and crane will automatically reset.</p> <p>Anti two-block (A2B) sensor may be limiting crane functionality. Check at the boom end that the A2B rail is not engaged by the travel block or stuck. If there is contact, all functions can be returned by either hoisting down or retracting the boom in.</p>
Overload sensor gets out of adjustment	See instructions to recalibrate on Page 23 of this manual.
Anti two-block microswitch gets out of adjustment	If the lever of the A2B rail is not properly engaging the microswitch, contact your distributor or RKI for replacement parts and instructions.
Crane will not lift load	Load may exceed crane capacity. Refer to the load chart. You may need to reposition the truck closer to the load. If hoist down works but not hoist up, then check overload and anti two-block systems referred to above.
Remote Control will not operate	Check for any loose, exposed or frayed wires. Make sure the switches return freely to the center position and are not sticking or loose. Inspect the plug pins for damage.
Sporadic Functions	Check the hot cable connections from the power source to the crane. (This includes the quick disconnect and the connection to the brass rod in the crane.) Check for proper ground between crane and service body, between service body and truck frame, and between truck frame and battery. With the truck engine running, check the power source to confirm the crane is receiving 13 volts for proper operations. A replacement battery, alternator or adding an additional battery may be necessary.

Always provide the serial number of the crane when contacting RKI for further troubleshooting questions (stamped in the nameplate located near bottom of rear cover).

RKI LIFETIME WARRANTY

This warranty applies to anything we have manufactured.

The warranty applies to whoever rightfully owns it right now.

If something goes wrong which we determine was our fault we will repair or replace your product. The warranty doesn't apply to normal wear and tear.

Be sure to call your local distributor if you have a problem. We need the opportunity to talk to you about it. We may ask you to email us pictures or ship the product back to us for inspection.

Parts that we use but don't manufacture are covered to the extent of the warranty we get from the company that does manufacture them.

No loss of use coverage. No freight coverage. Repairs have to be authorized by us, in writing, in advance. No coverage if the product has been changed in any way.

To qualify for warranty the product must have been treated with respect in regard to normal installation, maintenance, and usage.

Accidents and acts of God aren't covered.

This warranty will be in effect until we decide to change it.